

outremer

Grand Large Yachting

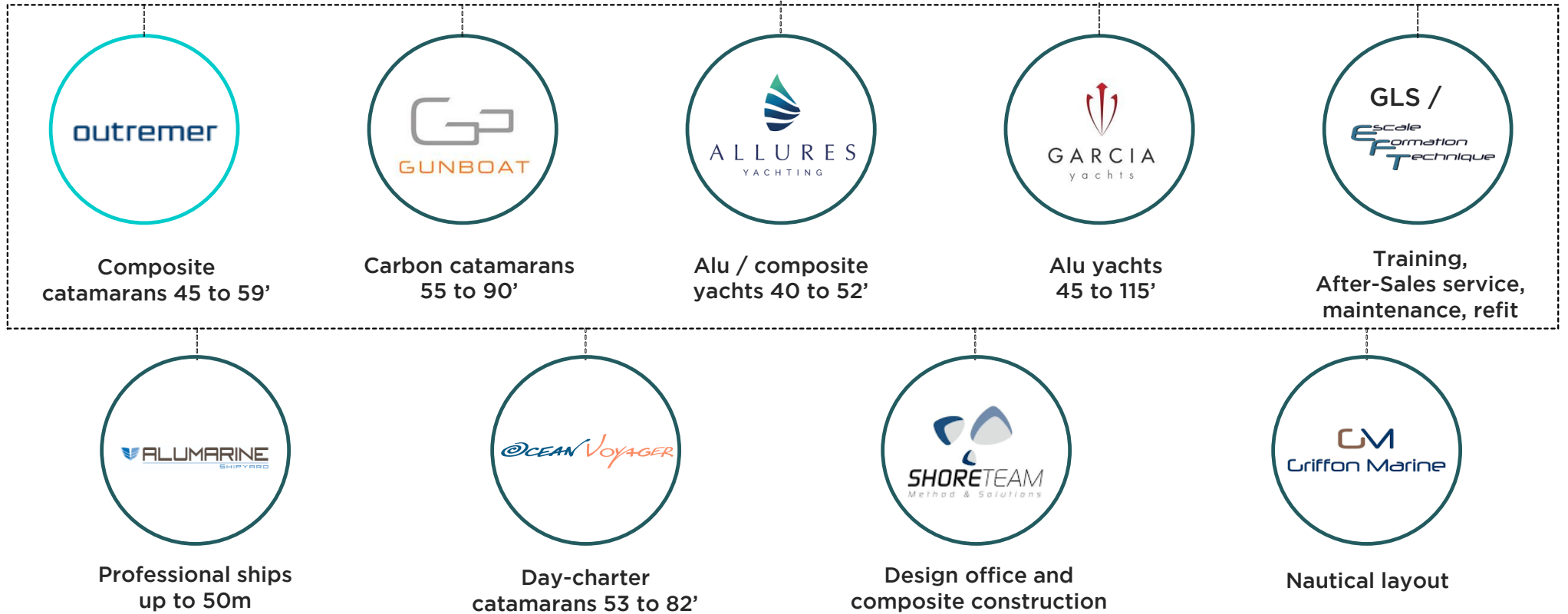

GRAND LARGE
YACHTING





GRAND LARGE
YACHTING

GRAND LARGE YACHTING
CONSOLIDATED TURNOVER
PER FINANCIAL YEAR

A GROUP ON THE RISE

0

2003

MILLION €
9.4

2013

MILLION €
25.7

2016

MILLION €
33.5

2017

MILLION €
42.2

2018

MILLION €
47.5

2019

MILLION €

60

2020
(Prev)

outremer

REMEMBER...



outramer



45



4X

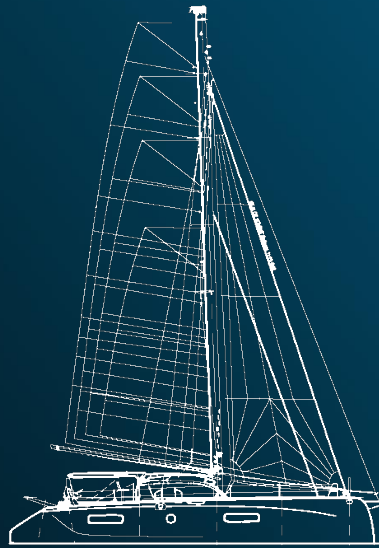

51

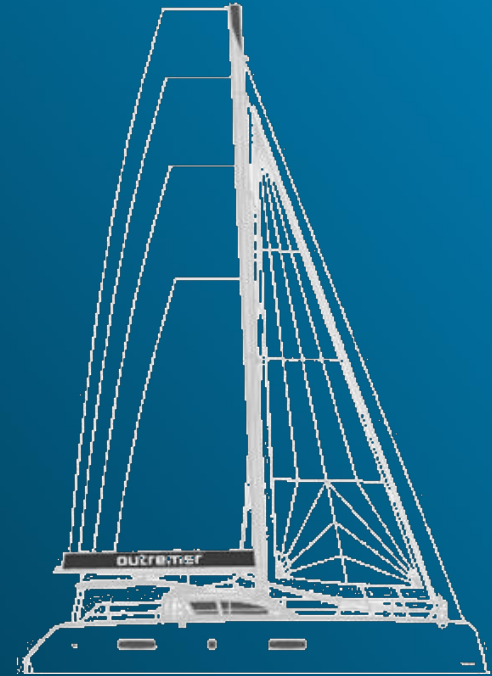

5X

35 years

of experience in the design long distance cruising catamarans.

Millions of miles

covered on every ocean.

310 feedback

received from our Outremer owners sailing all over the world and carefully considered.

1 team

made of the best naval architects and designers

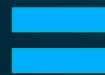

The quintessence of the Outremer experience in one boat combining quality of life, performance and sailing comfort

THE DREAM TEAM



**Patrick
Le Quément**

Design consultant



**Marc
Van Peteghem**

VPLP



**Franck
Darnet**

Darnet Design



The Outremer team



The Outremer community

A conception thoroughly planned.

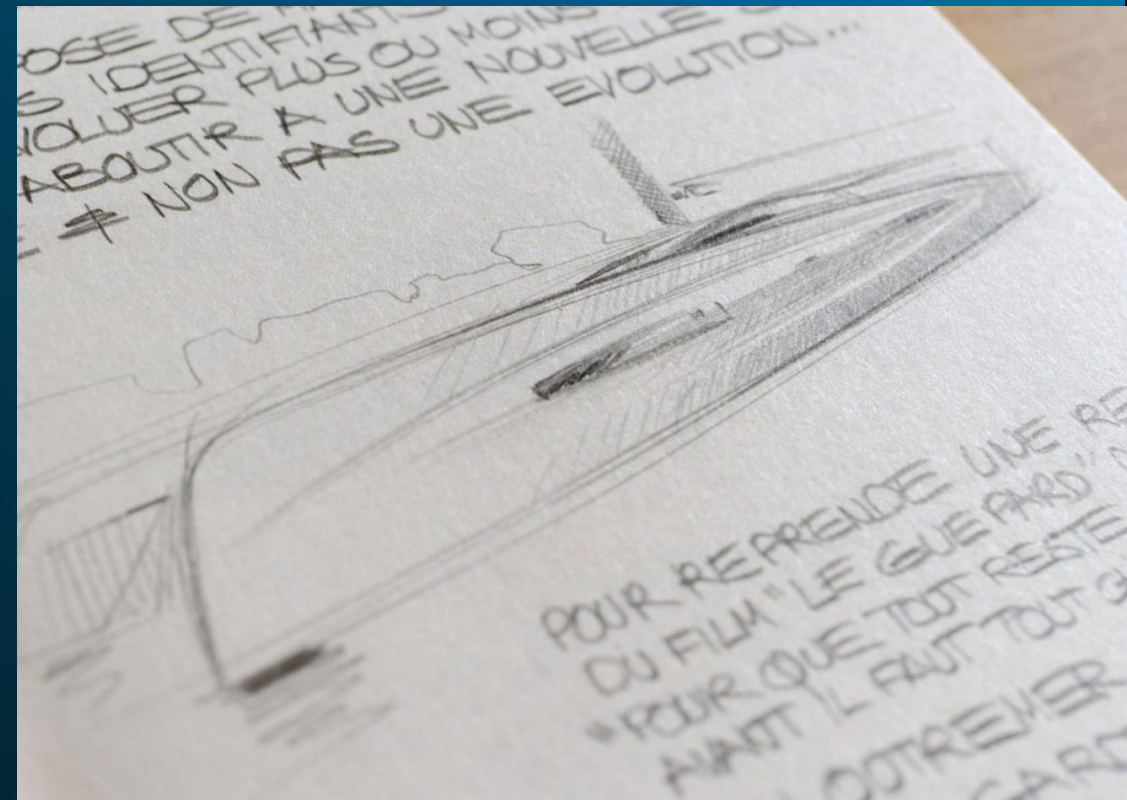

Powerful CFD tools to optimize the target speed range

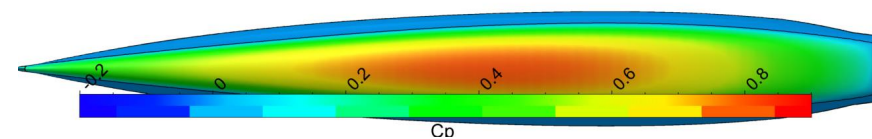
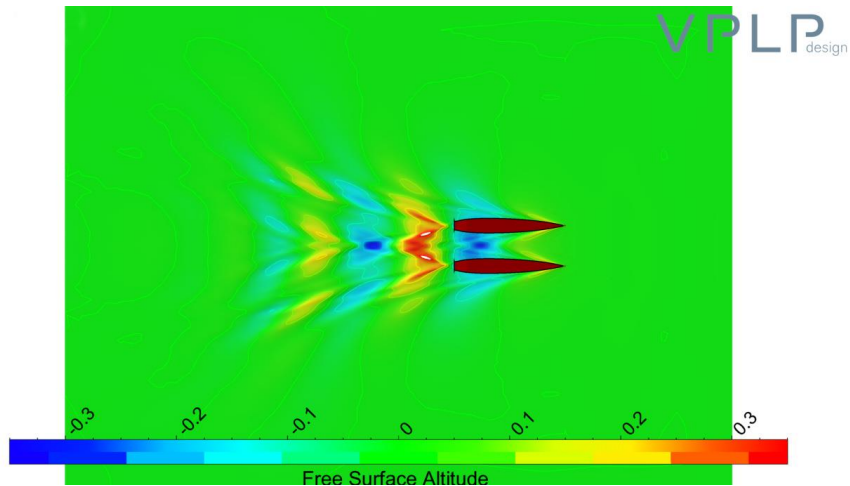
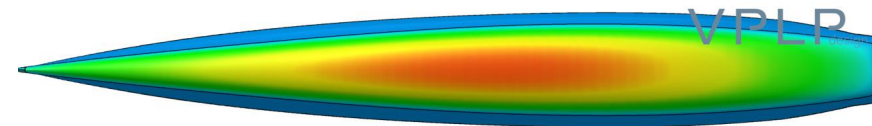
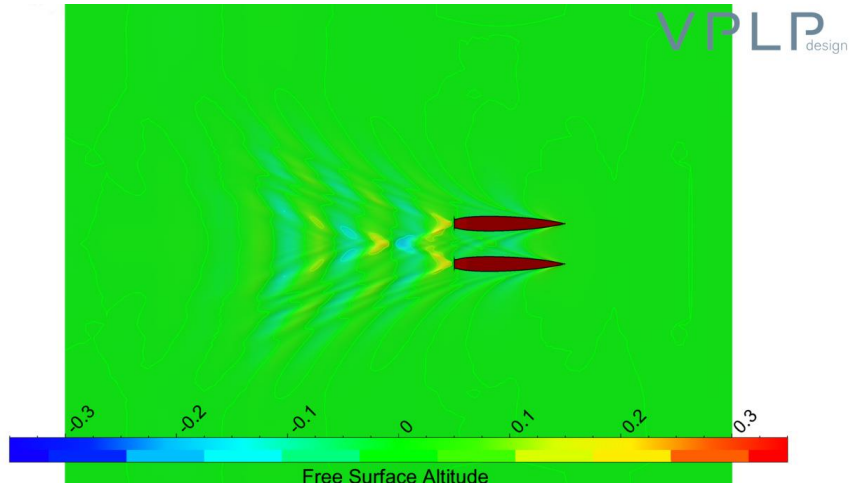

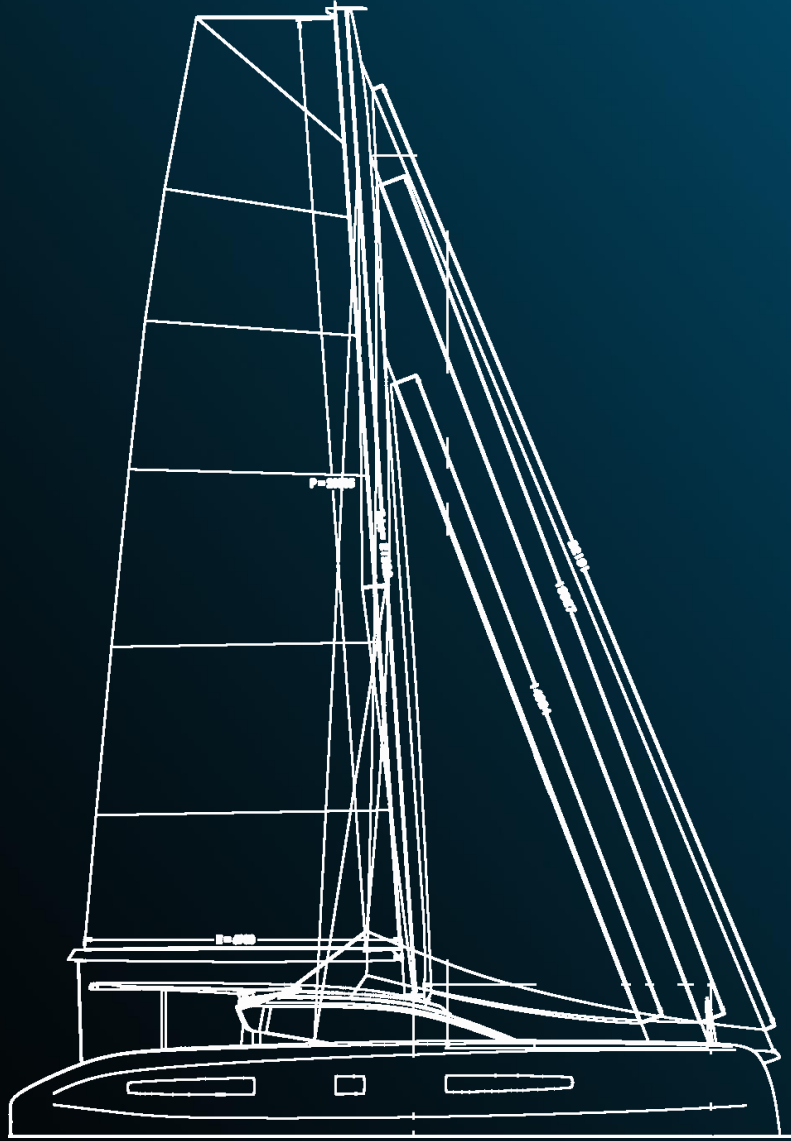

55

outremer

An ultra-accomplished and long-awaited boat that fits all naturally in the Outremer's range

outremer



45



4X

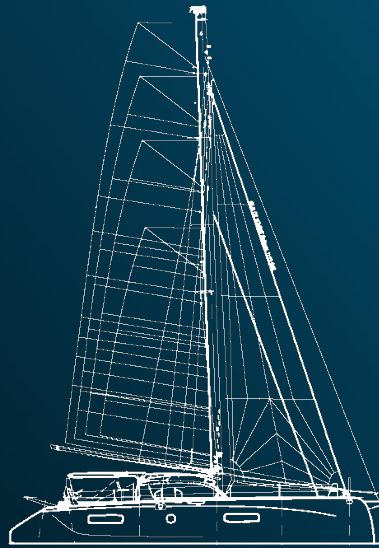

51

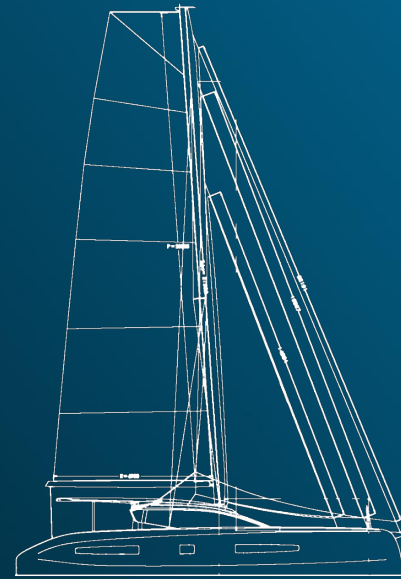

55



5X

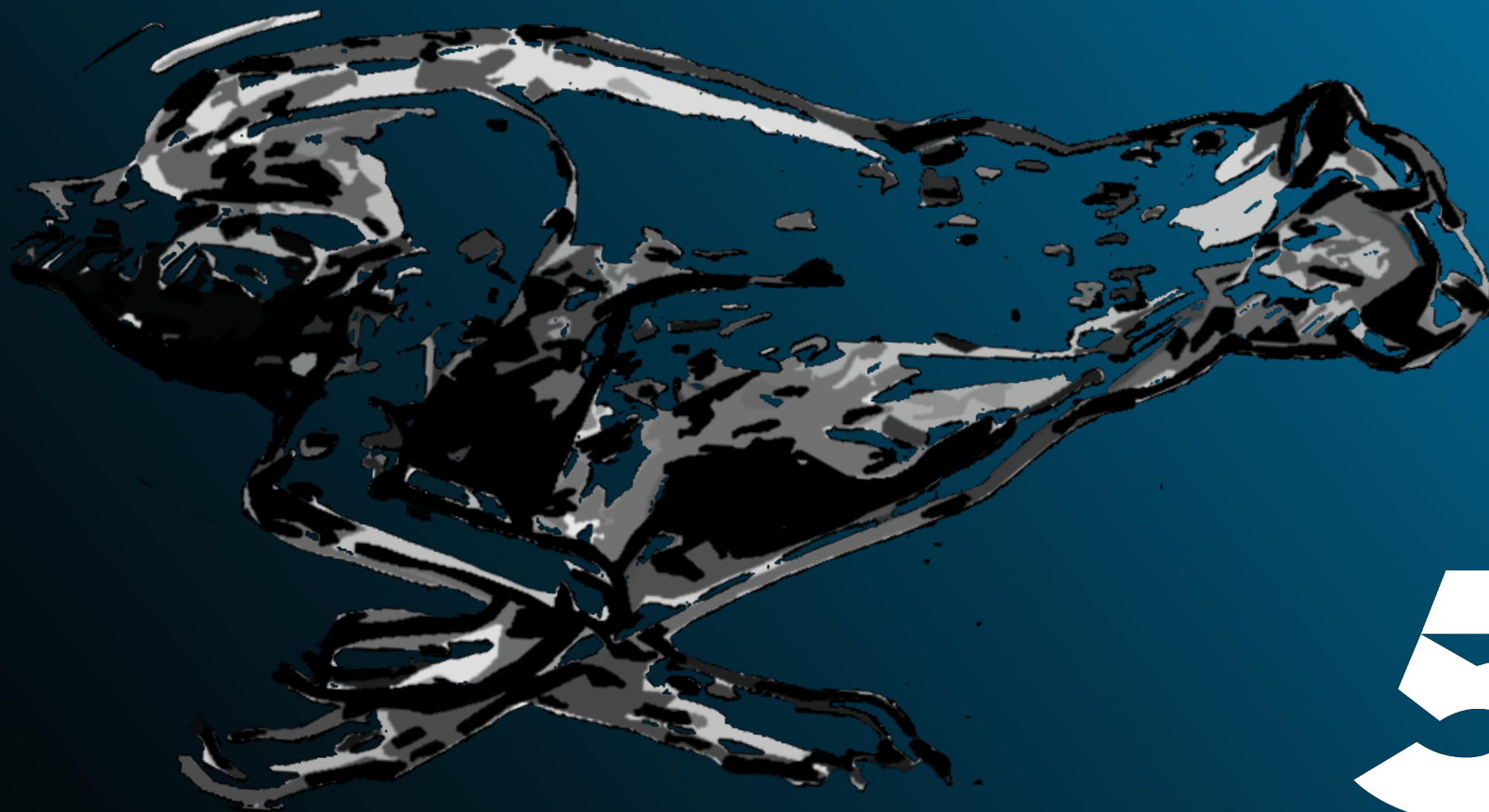

55
outremer

Outremer DNA with new features

Performance

Pleasure of sailing

Thought for short handed crew

Living on board (and Happy!)

A new standard in comfort for fast
catamarans

Eco-friendly

Seaworthiness qualities.
Packed with know-how and
marine experiences.

Construction of unequalled strength.
Best materials used with impeccable rigor.
All structural elements are directly laminated.
Solid fiber glass lamination bottom & separate watertight bulkheads.
Unsinkable.



Perfectly centered weight and low center of gravity

55
outremer



Powerful sail plan

Lightweight catamaran though innovations in construction techniques



- Maximized visibility for serene cruising
- An ergonomic bench, comfortable for two, making it possible to combine efficient monitoring with a unique pleasure of steering.



Winches set lower for easy control

Canting helms to combine exhilarating helm feeling and visibility.



The twin helm stations can be tilted either inboard into the cockpit or outboard to the side-deck and complete weather protection if needed.

55
outremer



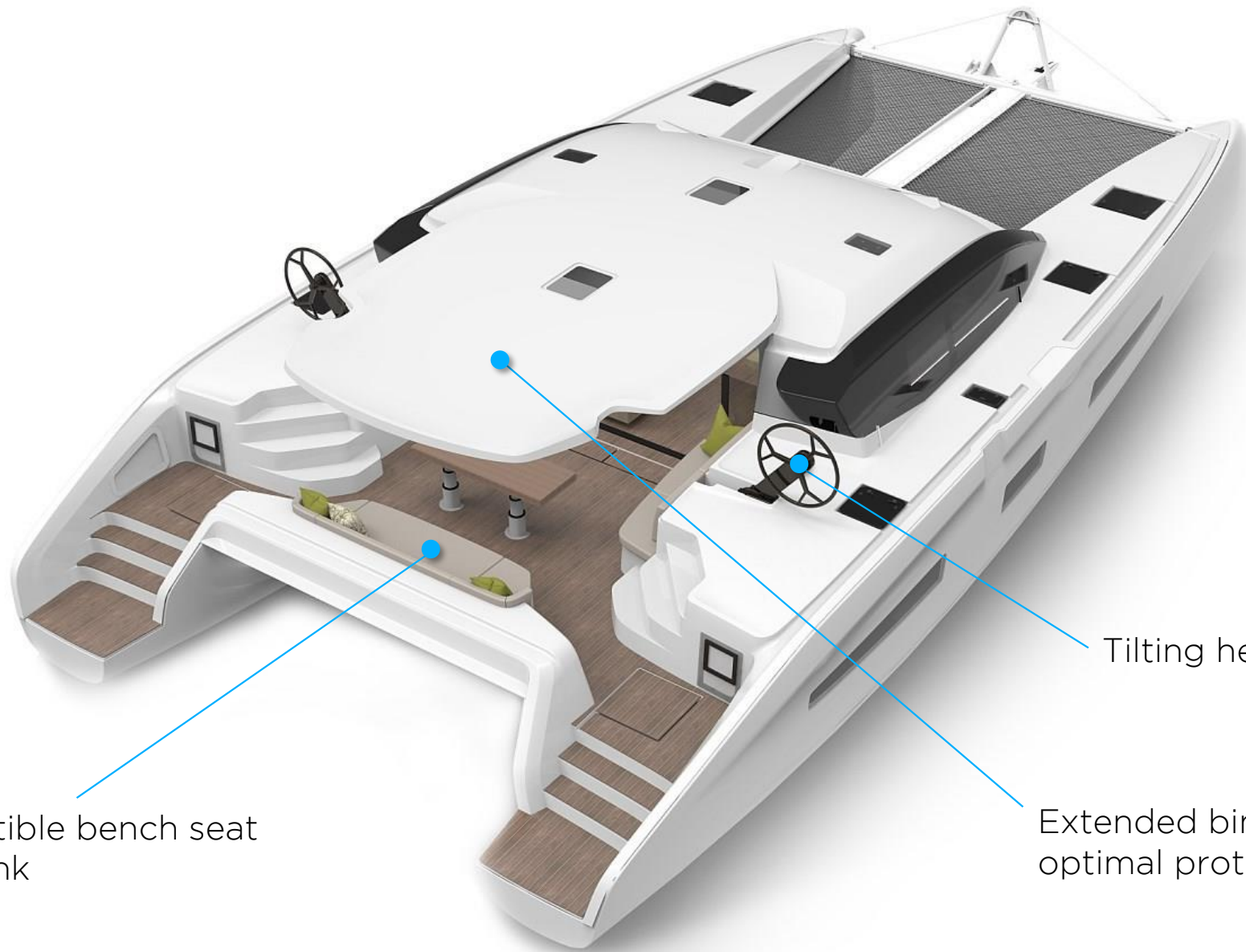

Convertible bench seat
into bunk

Tilting helm stations

Extended bimini for
optimal protection

Performance.

Outremer DNA

**Innovations to push performance and
pleasure of sailing one step further**

**Weight saving for more performance
or more payload**

Comfort.

More space, more flow, more
modularity for friendly moments.

Natural continuation
of the saloon

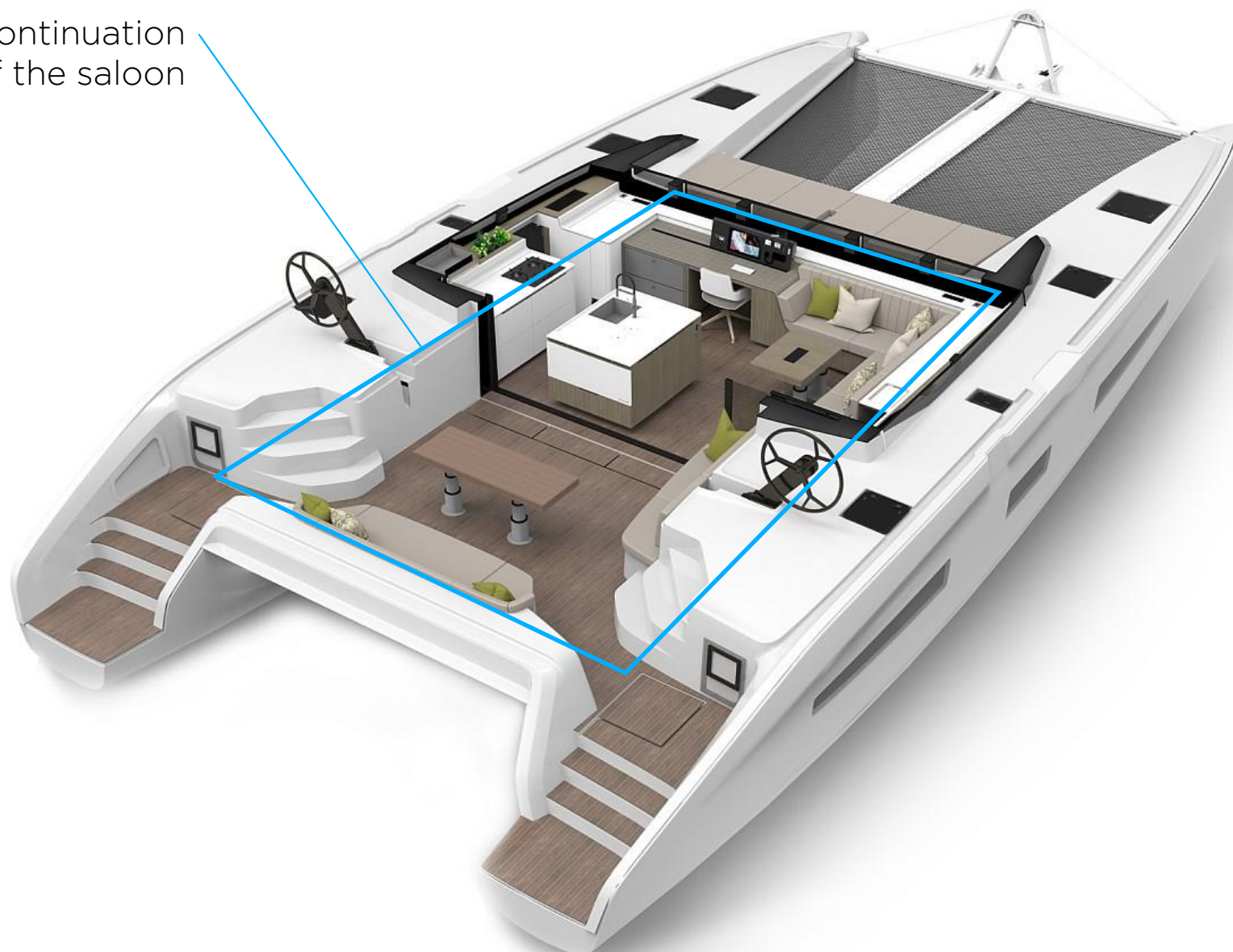

Large island galley
with foldable extension

Large and efficient
forward-facing
chart table





A customizable world
Create your atmosphere
Two complete worlds offered to start
with

Looking for

“WA” (Japanese for Peace, harmony, fullness)

Wa

55
outremer



Looking for
“Wa”

55
outremer



Happy

The spirit of voyage - cheerfulness - naturalness

55
outremer



Adapted to your needs
**Versatility of the configuration of the
boat to match your needs and
expectations
(office, workshop, additional cabin, ...)**

Sustainable

**The design of the boat inspired by
an eco-friendly approach.**

Light is ecological

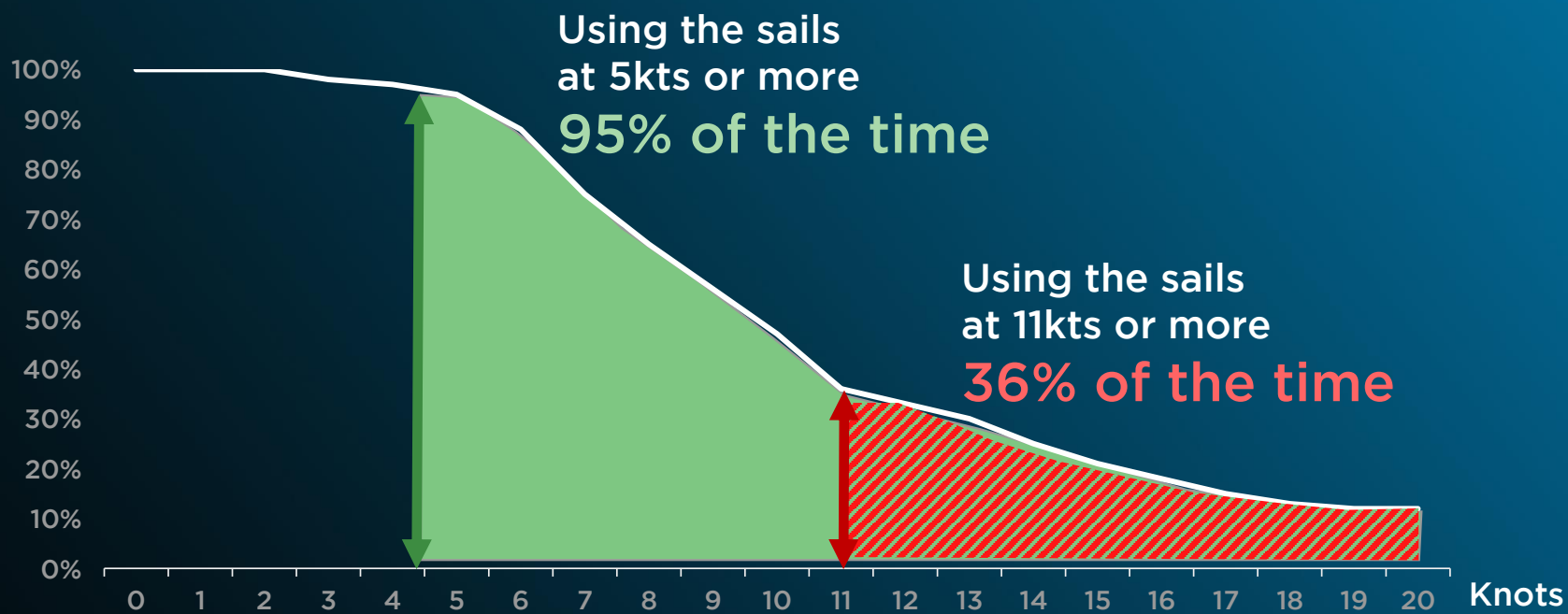

Data for west Mediterranean sea - june to september

Upwind performance :
safer, faster, more ecological and more comfortable

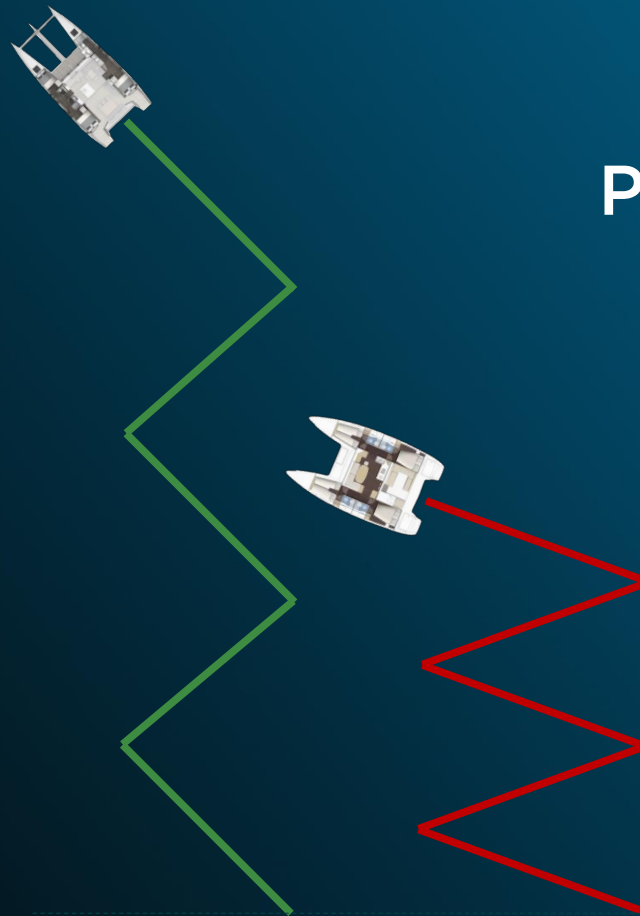
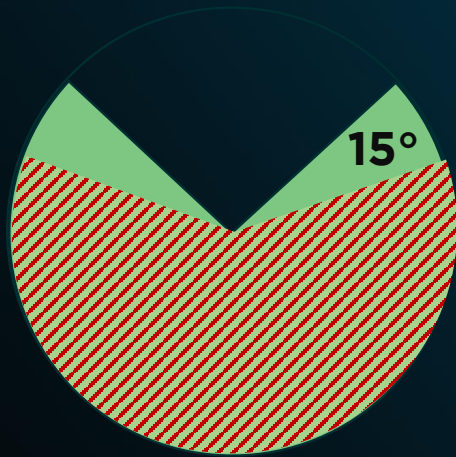

**Pinching 15° more
=
1,9 x shorter**

Well-designed natural ventilation system

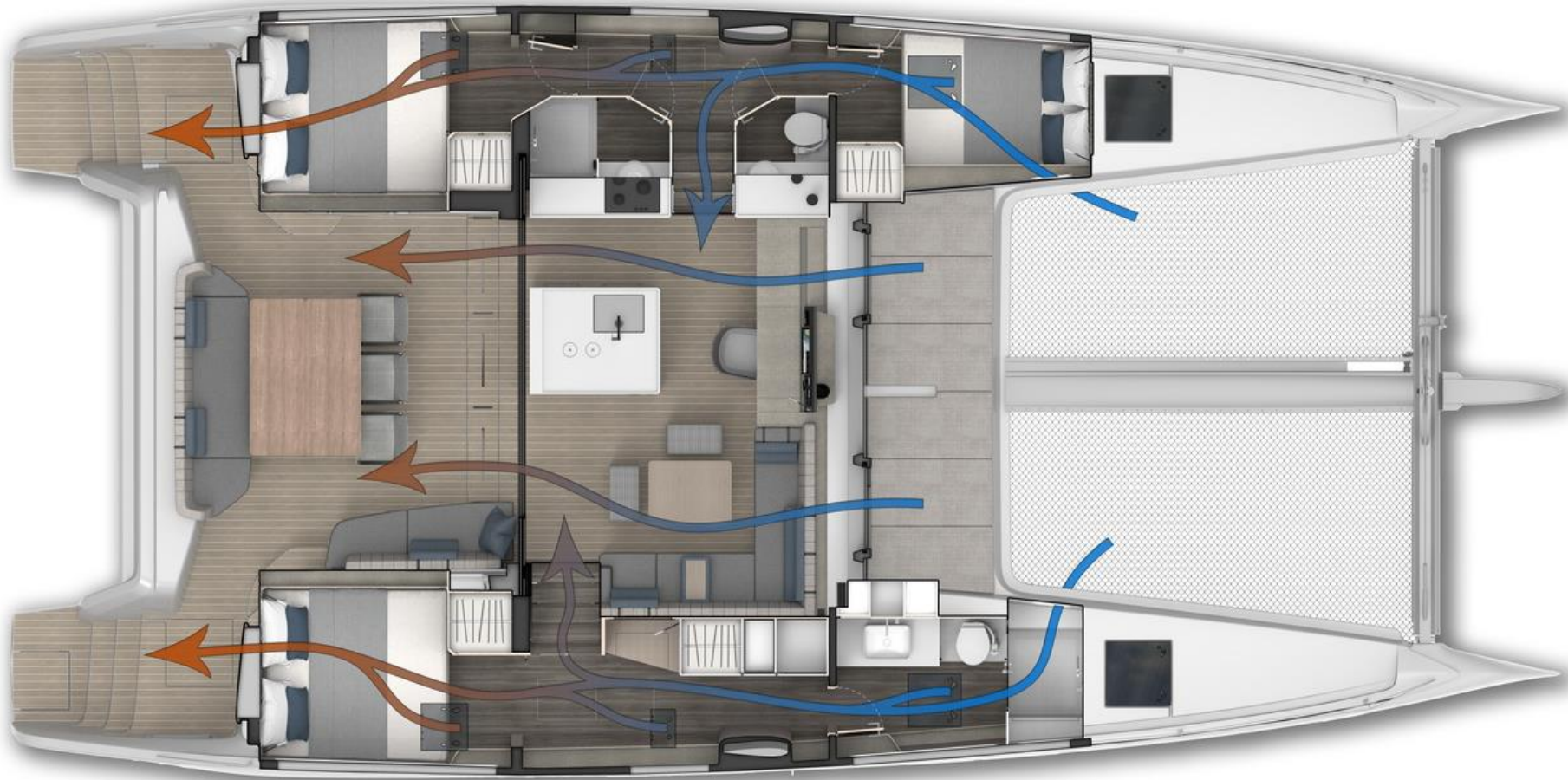

Full opening onto the cockpit for maximal flow.

55
outremer



Sustainable

More to come

Use of new materials

Carbon footprint analysis



55
outremer

Specifications

CONSTRUCTION :

OUTREMER YACHTING'S SHIPYARD, 34280
LA GRANDE MOTTE, FRANCE

General info	
Architects	VPLP
Design consultant	Patrick Le Quément
Interior design	Darnet Design
Length	16,73 m / 54.9 ft
Beam	8,22 m / 27.2 ft
Draught	0,9/2,4m / 3.9/8.2 ft
Air Draught (without antenna)	24,38 m / 80.7 ft
Displacement	13.4/18.5 t
Sail plan	
Mainsail	104 m ² / 1.120 sq ft
Genoa	68 m ² / 732 sq ft
Self tacking jib	48 m ² / 520 sq ft
Gennaker	145 m ² / 1.560 sq ft (option)
Spinnaker	220 m ² / 2.368 sq ft (option)
EC approval	8/26 p
Engines	2 x 60 hp



Q & A.